



ECO-FRIENDLY

ELECTRICAL HEAT EXCHANGER WAT- EX

SUITABLE FOR UP TO 30% H₂ FEED INTO THE GAS NETWORK

Directly heated gas preheater Type WAT-EX

The gas preheater type **WAT- EX** is designed especially for heating of natural gas. This kind of heat exchanger is used when natural gas has to be heated without big investments. The preheater is often installed as „starting“ heat exchanger in power stations and situated before gas turbines, but also in smaller pressure reducing stations. In case of upgrading an easy and reasonable solution is possible. In this compact type of heat exchanger the

heating insert is surrounded directly by natural gas. The maximum surface temperature is chosen so that the temperature can not be higher than the allowed one - according to the ex-protection - also when there is no gas flow. The apparatus will be designed according to the clients requirements. An inline design, as a standard feature in many reducing stations, can be delivered as well as any other positions of nozzles.

Design

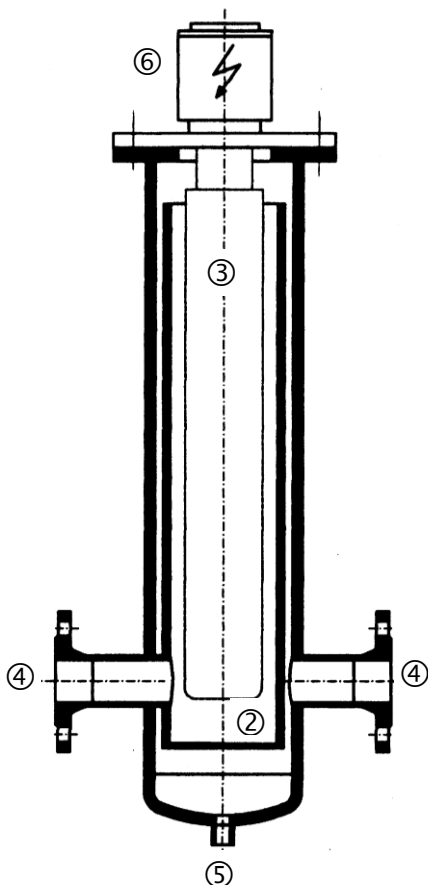

The electrical heating insert will be installed in a pressure vessel which is fabricated according to the demanded standards. The through-flow of natural gas is heated by the heater bundle. The heating insert is performed ex-protected. The pressure-resistant enclosure of the terminal box admits the use outdoor or in ex-exposed areas, too.

The temperature controller and limiter for the heater bundle is inserted in the terminal box. An optionally available, external temperature control device in combination with a gas temperature measuring can guarantee an efficient control.

- ① Shell tube
- ② Inner tube
- ③ Heater bundle
- ④ Connection nozzles
- ⑤ Drainage
- ⑥ Terminal box

Advantages

- Effective preheating by compact heating insert
- Low thermal loss by double tube construction
- Internal safety shut-down in case of unallowed bundle temperature
- Easy planning by different versions of nozzles design
- Gas-tight terminal box
- Low pressure loss

Directly heated gas preheater Type VF-EX

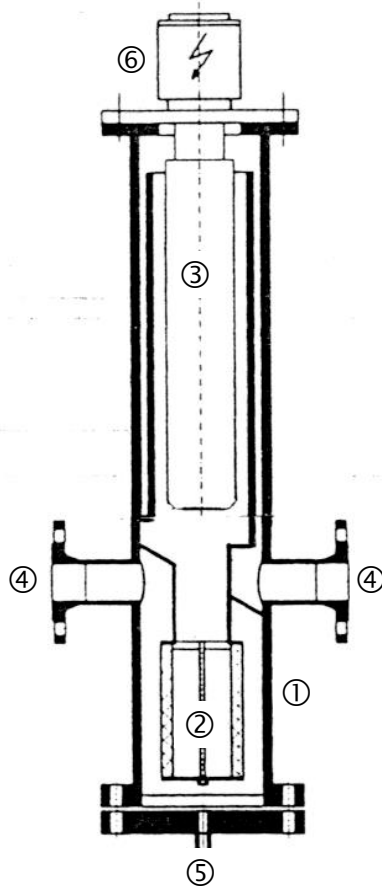

An especially effective and proven solution is the combination of heat exchanger type WAT- EX and cartridge filter. So the filtering of the gas as well as the heating can be executed in one apparatus.

Also this kind of preheater will be created according to the standards of client. The construction and design is conceived individually to achieve an optimal problem solution.

Advantages:

- Combined function of filtering and heating
- Compact design and less required space
- High efficient cartridge
- Proven feature

- | | |
|--------------------|----------------------|
| ① Filter casing | ④ Connection nozzles |
| ② Filter cartridge | ⑤ Drainage |
| ③ Heater bundle | ⑥ Terminal box |

Calculation and design of pressure vessels are usually according to DIN/AD and EU-Pressure Equipment Directive. Of course, other calculation codes e.g. ASME can be provided. The final approval is done by notified body like TÜV or according to clients specification.

The electric design occurs according to VDE or other EN standards. The heater bundle itself has a test certificate of a test institution admitted in the European Union. Other acceptance tests are possible by agreement.

As already mentioned, the design will be adapted to each specific case of application. Situation and size of gas connections, heating capacity and control devices are chosen according to the client requirements. The present description is an overview for standard heat exchangers only. For exact data and dimensions please refer to the detailed offer with dimensional sheet.

Technical data

Design pressure:	up to 100 bar
Design temperature:	-10 ... +100°C
on request:	-30 ... +150°C
Medium:	sweet gas
on request:	sour gas
Separation rate filter:	99,9% >3my
Replacement of filter:	at 0,8 bar pressure drop

Materials

Shell, bottoms: carbon steel, welded
 Flanges: C 22.8, ASTM
 Filter cartridge: cellulose, impregnated with phenolic resin and reinforced with polyester

Electrical heating insert

Power supply: 400 VAC (230 VAC)
 Type of protection: IP 55
 Ex-protection: EEx de IIC T1-6
 Material: stainless steel

HEAT

GAS AND OIL EQUIPMENT

HEAT energy GmbH

A-2362 Biedermannsdorf, Rheinboldtstraße 16
Tel.: +43 664824 1616
heat-energy@heatgroup.at
www.heatgroup.at

HEAT gaswärmetechnische Anlagen GmbH

D-34119 Kassel, Querallee 41
Tel.: +49 561 288 56-0
Fax: +49 561 288 56-20
office@heatgroup.de
www.heatgroup.de

HEAT Romania S.R.L.

RO-547 185 Cristesti (Targu Mures)
Strada Principală nr. 801
Tel.: +40 365 430 057
Fax: +40 365 430 057
office@heatgroup.ro
www.heatgroup.ro

HEAT Poland Sp. z o.o.

PL-40 761 Katowice, ul. Twarda 21
Tel.: +48 32 252 17 82
Fax: +48 32 252 17 82
info@heatgroup.pl
www.heatgroup.pl

QR-Code

Prospekt

HEAT energy Kft.

H-8800 Nagykanizsa, Erdész u. 28.
Tel.: +36 93 537 140
Fax: +36 93 537 142
heat-energy@heatgroup.hu
www.heatgroup.hu

LOG Oiltools Kft.

H-8800 Nagykanizsa, Erdész u. 28.
Tel.: +36 93 537 140
Fax: +36 93 537 142
info@logoiltools.hu
www.logoiltools.hu

HEAT Hungary Kft.

H-1047 Budapest, Attila u. 63.
Tel.: +36 1 369 15 32
Fax: +36 1 369 72 16
heatgroup@heathungary.hu
www.heathungary.hu

HEAT Bulgas OOD

BG-1113 Sofia, Fr. Joliot Curie Str. 20, Office 803
Tel.: +359 88 945 2607
office@heatgroup.bg
www.heatgroup.at

QR-Code

Anfrageblatt

HEAT Holding International GmbH

A-2362 Biedermannsdorf, Siegfried Marcus-Straße 9
Tel.: +43 2236 73 130
Fax: +43 2236 73 130-300
ghi@heatgroup.at
www.heatgroup.at