

TURBINE METER SERIES

FMT-S



 **FMG**
Flow Meter Group

The best way to predict the future is to create it

Introduction

The FMT-S turbine meters are robust and designed to perform on the highest level of accuracy. Unique for these meters is the fact they comply with all international standards and are approved for custody transfer even with smallest possible installation length. The actual flow sensor, an exchangeable cartridge, has a built-in multi stage flow conditioner enabling the meter to be installed with limited (1 x DN) straight in- and outlet sections. All tested and proved according perturbation test as per international standards.

The cartridge can be pre-calibrated, under both low and high pressure conditions, then exchanged on-site. The cartridge is supported in O-rings and isolated from the body, hence unaffected by any influences of the housing.

To reduce transportation cost, optimize the corrosion protection and improve safety in handling, the FMT-S series of turbine meters are also available with low weight aluminium meter bodies. As an example, the weight of a 12" (DN300) ANSI300 FMT-S is less than 45 kg.

Principle

The operation of the FMT-S series of turbine meter is based on the measurement of the velocity of gas. The flowing gas is accelerated and conditioned by the integrated multi stage flow conditioner. The multi stage flow conditioner prepares the gas flow profile by removing undesirable swirl and asymmetry before the gas flows over the freely rotating turbine wheel.

The dynamic forces of the flowing gas cause the rotor to rotate. The turbine wheel is mounted on the main shaft, with high-precision, low-friction ball bearings.

The turbine wheel has helical blades that have a known angle relative to the gas flow. The gas flow drives the turbine wheel at an angular velocity, which is proportional with the gas velocity. Using a gearing mechanism, the rotating turbine wheel drives the mechanical counter.

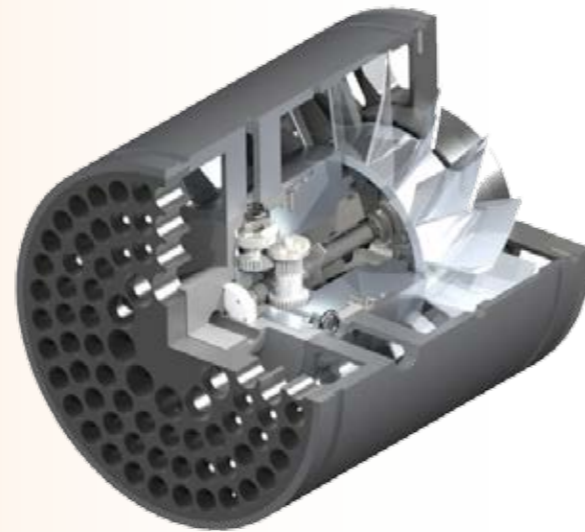

Applications

The unique FMT-S turbine meter is suitable for custody transfer gas measurement of all non-corrosive gases such as natural gas, propane, butane, air, nitrogen, hydrogen, etc. for low and high operating pressures. Special constructions can be supplied for use under extreme conditions like high temperatures or corrosive gases. Standard FMT-S bodies up to 8" (DN 200 mm) ANSI150 or PN10/PN16 come with threaded flanges. Larger Sizes or higher pressure ratings up to 24" ANSI600 are available in steel.

The FMT-S has a length of just 1 x DN. For flange ratings up to ANSI300 and PN40, the body is available in aluminium (steel on request). Due to the extremely low weight of these aluminium bodies, the meter can be transported easily and exchanged without special equipment.

Accuracy

Each FMT-S turbine gas meter is tested with atmospheric air to traceable calibrated references. The error limits are typical half of those allowed by MID, EN standards or OIML recommendations. For pressures of above 8 bar even narrower limits are available. Optionally, meters can be calibrated with natural gas at pressures up to 100 bar, using test installations traceable to primary standards.

Typical metrological characteristics

Accuracy 0,2 Q_{max} to Q_{max}: ± 1% or better
 Accuracy Q_{min} to 0,2 Q_{max}: ± 2% or better
 Repeatability: better than 0,1%

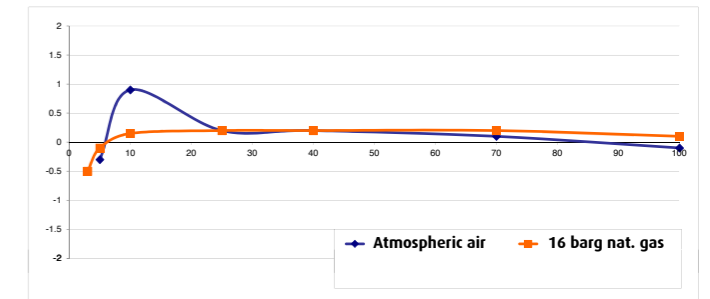

Measuring range

The measuring range of the FMT-S turbine meter is determined under atmospheric conditions and meets with, and generally exceeds, the international standards. At higher operating pressures the measuring range of the turbine meters will increase since the required kinetic energy transfer to the turbine rotor occurs at lower velocities. The following equation may be used to estimate the minimum flow rate of the meter for various operating conditions.

Pressure Loss

The average pressure loss (see tables page 6) of the FMT-S turbine meter is measured with atmospheric natural gas with a relative density of 0.6 at one (1) diameter upstream to one (1) diameter downstream of the meter on straight pipe of the same size as the meter. The pressure loss across the FMT-S turbine meter for various gases and other operating pressures may be approximated from the following equation:

Measuring range

$$Q = Q_{min} \sqrt{\frac{P_{atm}}{P} \times \frac{1.29}{\rho}} \text{ [m}^3/\text{h]}$$

ΔP_2 = Pressure drop at P and Q_{max}
 ΔP_1 = Pressure drop at Q_{max} (See tables pages 6 and 7)
 P = Operating pressure of the meter in bar absolute
 P_{atm} = Atmospheric pressure in bar absolute (1.01325 bara)
 Q = Instantaneous flow in m³/h

Pressure loss

$$\Delta P_2 = \Delta P_1 \times \frac{d}{0.6} \times \left(\frac{P}{P_{atm}}\right) \times \left(\frac{Q}{Q_{max}}\right)^2 \text{ [Pa]}$$

Q_{max} = Max. Flow rate in m³/h
 Q_{min} = Min. Flow rate at atmospheric pressure in m³/h
 d = Relative density of the gas (air = 1)
 ρ = Density of the gas at atmospheric pressure



Main Features

- Flow range 3- 25.000 m³/h
- Diameters DN50 - DN600 (2" - 24")
- Pressure rates PN 10 - 100, ANSI 150 - 600
- Pressure rates PN 10 - 100, ANSI 150 - 600
- Compliant with EN12261:2002
- Compliant with EN12261:A1-2006
- Compliant with OIML R137 1&2 (2014)
- Compliant with MID 2014/32/EU
- MID temperature range -25 to +70°C
- Short length
- Removable meter cartridge
- 1 x DN straight inlet section required
- Life time lubrication / oil flushing lubrication system
- Multipurpose exchangeable index
- Tamper proof IP67 sealed index
- Seals according EN 549 (seals for gas appliances and gas equipment)

Installation

The FMT-S fulfils all the requirements of the European and International directives. In particular those of the OIML, ISO and EN. With the special integrated flow straightener, the FMT-S turbine meter eliminates the effect of severe perturbations with an straight inlet and outlet piping of 1 x DN. This permits the design of very compact installations without losing accuracy.

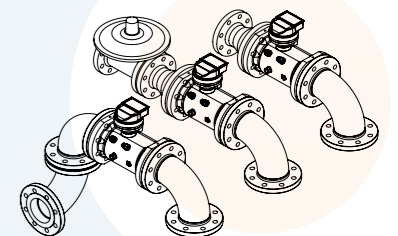

Minimum Installation Configurations

Index

The basic index consists of an UV-resistant polycarbonate cover, glued (IP67) to an aluminium frame. The aluminium frame will give strength to the index and as such sufficient protection against mechanical interference (Tampering). The index can be rotated over 350° for all directions. The index can be equipped with multiple LF switches (Reed or Wiegand principle), "Normally Closed" tamper contacts and encoder technology. The LF pulsers and its driving magnet are shielded to overcome tampering with an externally applied magnetic field. Magnetic fields up to 500 mT will not have an effect on the pulse counting. The index can be equipped with several options making the meter prepared for the future:



Double reed plus normally closed contact:

all basic indexes are equipped with an double reed and a normally closed contact. Reverse Flow Lock: In order to avoid tampering by reverse flow, the index or instrument drive can be equipped with a Reverse Flow Lock.

Wiegand Pulsers:

The Index can be equipped with multiple Wiegand pulsers. The Wiegand pulsers do have significant advantages over the traditionally used Reed contacts. Wiegand sensors do not face "bouncing" problems and the actual live time is not limited as much as the traditional Reed contacts.

Adjustable with
DIN-3374 sets



Intelligent Index/Encoder:

The index can be equipped with an intelligent encoder. The encoder sends out the total volume with an interval of 400 msec. The encoder uses a standard NAMUR serial data format, and can be modified to special applications on request. The encoder is powered by one AA cell battery guaranteed for 12 years of operation. On request two AA cells can be installed for a guaranteed life time of 20 years. The encoder is equipped with a special Hall sensor to detect and register interferences from external magnets. Several programmable inputs/outputs are available for advanced - anti fraud - functions.



Lubrication

The FMT-S series incorporates high quality precision bearings. For optimal performance and long life time, it is recommended that the bearings are flushed and lubricated on a regular base. FMT series of turbine meters can be equipped with several types of lubrication systems or with life time lubrication. FMG recommends to use the lubrication systems. In case of a lubrication system, an integrated splash vane will distribute the oil to all the moving parts and will flush the bearings. Recommendations as to when to lubricate turbine meters varies by product type, operating conditions, customer procedures, and regulatory requirements. Meter performance is optimized by flushing contamination from the bearings and refreshing or adding of oil during operation.



Heavy duty bearings

Since the forces on the main bearings are directly related to the density (operating pressure) of the gas, the FMT-S series incorporates bearings dedicated to the working pressure. FMT-S(w) turbine meters which have a low working pressure are equipped with lighter bearings then the meters which are used at higher working pressures. This way, the best measuring ranges and life times can be guaranteed.



High Frequency Sensors

FMT-S Turbine meters can be equipped with several types of high frequency sensors.

HF main shaft: this high frequency sensor generates two independent phase shifted signals and as such the flow direction can be monitored. The signal generated complies with Namur.

HF turbine wheel: this HF sensor can be used to check the condition of the turbine wheel (missing blades) by comparing the pulses with the HF main shaft.

For both sensors, the electrical separation between the hazardous and non-hazardous areas is accomplished by an intrinsically safe isolation amplifier

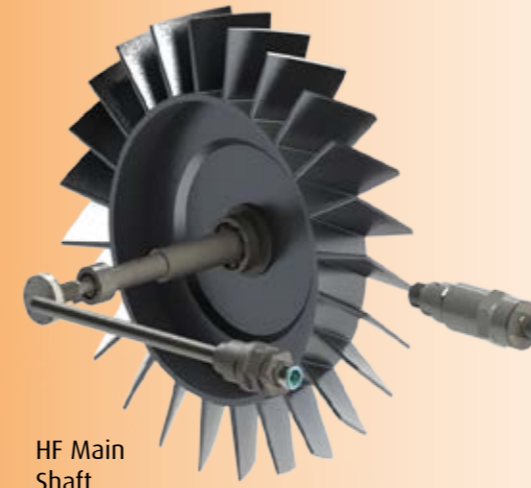

HF Main Shaft

HF Turbine Wheel

Low weight body construction

One of the important features of the FMT-S is the low weight body construction. With the latest techniques and experiences with different materials an optimized body construction was developed, which is still compliant with the Pressure Equipment Directive 97/23/EC requirements.

Flow Meter Group can provide the FMT-S with two types of installation: a flanged type and a wafer type construction. Therefore Flow Meter Group can always find the best construction to suit the project.

Combined with the short measurement unit which is MID 2004/22/EC and OIML R-137 approved most custody transfer meters can be installed without any cranes. The meter can be easily carried by a single person.



Technical Specification

Metrological approvals:

Compliant with EN12261:2002
Compliant with EN12261:A1-2006
Compliant with OIML R137 1&2 (2014)
Compliant with MID 2014/32/EU

ATEX approvals:

Sensors compliant with Ex ia IIC T4... T6 Gb (-40°C ≤ Ta +70°C)
Encoder compliant with Ex ib IIB T3... T6 Gb (-25°C ≤ Ta +55°C)

Flow rates:

3 m³/h up to 25.000 m³/h

Nominal diameters:

From DN50 to DN600 mm (2" to 24").

Max. working pressure:

Up to 100 bar depending on the body material and flanging

Mounting position:

Horizontally or vertically

Body

Compliant to Pressure Equipment Directive 2014/68/EU

Temperature Range:

ATEX: -25°C to +70°C

MID: -25°C to +70°C (lower temperatures on request)

PED: -20°C to +70°C (lower temperatures on request)

Materials:

Body (Standard):

Low weight aluminum / steel

Body (Optional):

Low temperature steel

Cartridge:

Aluminum

Straightening vane:

Aluminum

Turbine wheel:

Aluminum

Bearing block:

Stainless steel / aluminum

Bearings:

Stainless steel

Shafts:

Stainless steel

Gears:

POM

Index frame:

Aluminum

Index frame:

Polycarbonate ECI

Technical Specification

Dimensions

Size (mm)	G-value (-)	Qmax (m³/h)	Qmin			ΔP ₁ (NG)* (Pa)	LF (imp/m³)	HF Main** (imp/m³)	HF Wheel** (imp/m³)
			Atm. Air (m³/h)	4 bar NG (m³/h)	8 bar NG (m³/h)				
80	G100	160	8	5	3	900	1	1845	64540
	G160	250	13	8	5	900	1	22560	67675
	G250	400	20	13	8	900	1	8235	28815
100	G160	250	13	8	5	900	1	8025	24065
	G250	400	20	13	8	900	1	3915	13700
	G400	650	32	20	13	900	1	2340	9350
150	G400	650	32	20	13	900	1	4475	6715
	G650	1000	50	32	20	900	1	2950	5165
	G1000	1600	80	50	32	1600	0.1	1435	2865
200	G650	1000	50	32	20	900	1	2950	5165
	G1000	1600	80	50	32	900	0.1	1435	2865
	G1600	2500	125	80	50	1600	0.1	885	1770
250	G1000	1600	50	32		900	0.1	775	2320
	G1600	2500	80	50		900	0.1	440	1310
	G2500	4000	130	80		1600	0.1	440	1310
300	G1600	2500	80	50		900	0.1	440	1320
	G2500	4000	130	80		900	0.1	245	740
	G4000	6500	200	130		1600	0.1	245	740
400	G2500	4000	130	80		900	0.1	220	655
	G4000	6500	200	130		900	0.1	125	370
	G6500	10000	320	200		1600	0.1	125	370
500	G4000	6500	200	130		900	0.1	95	285
	G6500	10000	320	200		900	0.1	54	162
	G10000	16000	500	320		1600	0.01	54	162
600	G6500	10000	320	200		900	0.1	28	84
	G10000	16000	500	320		900	0.01	28	84
	G16000	25000	800	500		1600	0.01	28	84

Dimensions FMT-S (Flanged)								Dimensions FMT-S (Wafer)					
C (mm)	E (mm)	H (mm)	L*** (mm)	ALU (kg) < 21 bar	STEEL (kg) < 21 bar	STEEL (kg) < 51 bar	STEEL (kg) < 101 bar	C (mm)	E (mm)	H (mm)	L*** (mm)	ALU (kg)	STEEL (kg)
175	95	175	120	8	27	27	27	175	95	178	120	7	13
175	95	175	120	8	27	27	27	175	95	178	120	7	13
175	95	175	120	8	27	27	27	175	95	178	120	7	13
192	112	185	150	11	47	47	55	192	112	190	150	8	15
192	112	185	150	11	47	47	55	192	112	190	150	8	15
192	112	185	150	11	47	47	55	192	112	190	150	8	15
212	138	212	175/180	19	79	79	102	212	138	213	175/180	12	25
212	138	212	175/180	19	79	79	102	212	138	213	175/180	12	25
212	138	212	175/180	19	79	79	102	212	138	213	175/180	12	25
243	168	238	200	26	86	112	152	243	168	243	200	15	35
243	168	238	200	26	86	112	152	243	168	243	200	15	35
243	168	238	200	26	86	112	152	243	168	243	200	15	35
236		282	250/375	-	124	162	244	236		282	250	43	87
236		282	250/375	-	124	162	244	236		282	250	43	87
236		282	250/375	-	124	162	244	236		282	250	43	87
236	As per flange dimension	283	300/450	-	175	225	303	236	As per flange dimension	283	300	51	99
236		283	300/450	-	175	225	303	236		283	300	51	99
236		283	300/450	-	175	225	303	236		283	300	51	99
295	As per flange dimension	328	400/600	-	292	384	530	295	As per flange dimension	328	400	93	221
295		328	400/600	-	292	384	530	295		328	400	93	221
295		328	400/600	-	292	384	530	295		328	400	93	221
375	As per flange dimension	380	500/750	-	342	492	704	375	As per flange dimension	380	500	133	334
375		380	500/750	-	342	492	704	375		380	500	133	334
375		380	500/750	-	342	492	704	375		380	500	133	334
425	As per flange dimension	430	600/900	-	511	749	1009	425	As per flange dimension	430	600	176	457
425		430	600/900	-	511	749	1009	425		430	600	176	457
425		430	600/900	-	511	749	1009	425		430	600	176	457

* ΔP₁ is measured under atmospheric conditions with natural gas with relative density of 0.6 (Air = 1)
 ** Values may vary 5% due to machining tolerances
 *** Different lengths on request

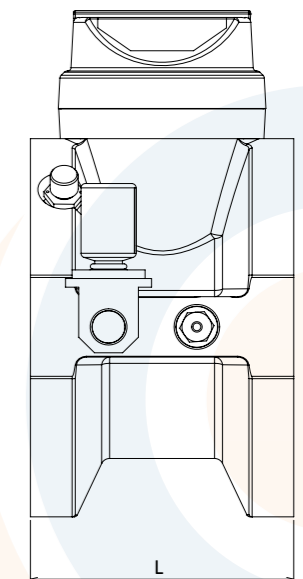
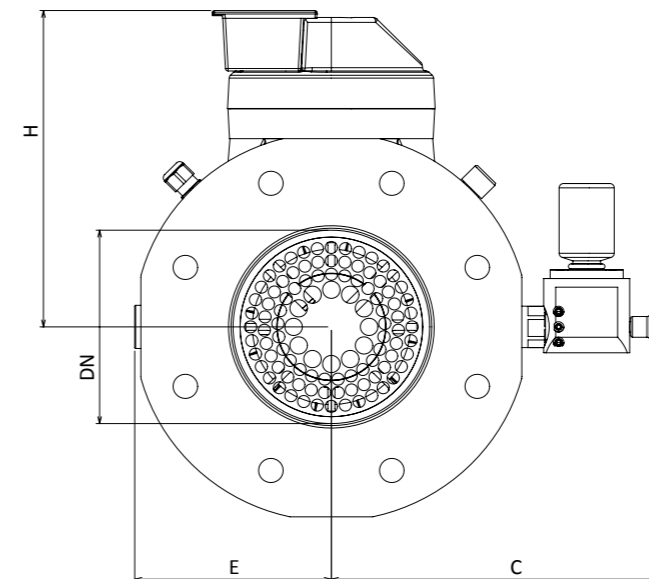

About us

Flow Meter Group B.V. (FMG)

FMG is an engineering/manufacturing company specializing in the development and production of energy and gas measurement systems. Located in the Netherlands, FMG produces a wide range of rotary and turbine gas meters, volume conversion devices, master meters and calibration benches. Unique product features include self diagnosis and tamper prevention. All products and services are certified by the Dutch NMI and comply with the latest EU and/or OIML directives.

Flow Meters

FMG offers a large variety of flow meters ranging from very small (100 dm³/h) up to very large (40.000 m³/h) flow rates and in pressures from atmospheric to 100 bar (1440 psi). All FMG meters comply with international safety and metrological standards. Meters designated for fiscal use are tested, certified and approved by the Netherlands Metrological Institute NMI.

FMG has added extra features to the meters in terms of increased accuracy, protection from manipulation, increased rangeability and superior performance in order to go beyond the minimum requirements of the existing standards.



Positive Displacement Meters



Master Meters



Turbine Meter Series FMT-Lx



Flow Computers



Test Benches

Contact



Flow Meter Group B.V.
Innovatieweg 32
7007 CD Doetinchem
The Netherlands

Tel: +31 (0)315 651 556
Fax: +31 (0)315 651 448

E-mail: info@flowmetergroup.com

